

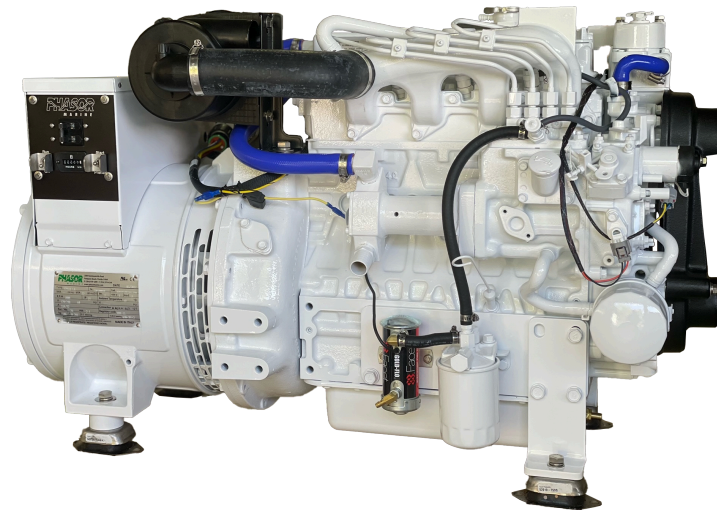

Operator's and Installation Manual

K3-14.0KW - K4-21.0KW





READ AND SAVE THIS MANUAL

Operation and Safety Precautions

Before operating the generator set, read the Operator's Manual and become familiar with it and your unit. Safe and efficient operation can be achieved only if the unit is properly operated and maintained. Many accidents are caused by failure to follow fundamental rules and precautions.

Throughout this manual, you will notice symbols that alert you to potentially dangerous conditions, either to the operator, service personnel, or the equipment itself.

 **DANGER** This symbol warns of immediate hazards which will cause severe personal injury or death.

 **WARNING** This symbol refers to a hazard or unsafe practice which could result in severe personal injury or death.

 **CAUTION** This symbol refers to a hazard or unsafe practice which will or can result in personal injury and/or product or property damage.

FUEL, ENGINE OIL, AND FUMES ARE FLAMMABLE AND TOXIC. Fire, explosion, and personal injury can result from improper practices.

- Benzene and lead, found in some fuels, have been identified by some state and federal agencies as causing cancer or reproductive toxicity. When checking, draining or adding fuel, take care not to ingest, contact the fuel or breath the fumes.
- Used engine oils have been identified by some state or federal agencies as causing cancer or reproductive toxicity. When checking or changing engine oil, take care not to ingest, breathe the fumes, or contact used oil.
- Do not fill fuel tanks with the engine running. Do not smoke around the generator set area. Wipe up any oil or fuel spills. Do not leave oily rags in engine compartment or on the generator set. Keep generator and surrounding area clean.
- Inspect fuel system before each operation and periodically while running.
- Equip the engine fuel supply with a positive shutoff.
- Always disconnect the battery ground (-) lead first and reconnect it last. Make sure you connect the battery correctly. A direct short across the battery terminals can cause an explosion or severe damage. Do not smoke while servicing batteries. Hydrogen gas given off during charging is very explosive.
- Keep a fire extinguisher available in or near the engine compartment and in other areas throughout the vessel. Use the correct extinguisher for the area. For most types of fires, an extinguisher rated ABC by the NFPA is available and suitable for use on all types of fires except alcohol.

EXHAUST GASES ARE DEADLY

- Provide adequate ventilation. Equip the bilge with a power exhauster.
- Be sure propulsion and generator set engine exhaust systems are free of leaks. Perform thorough, periodic inspections of the exhaust system and make repairs immediately.
- Never sleep in the vessel with the generator set running unless the vessel is equipped with an operating carbon monoxide detector.

HOT COOLANT CAN CAUSE SEVERE PERSONAL INJURY

- Hot coolant is under pressure. Do not loosen the coolant pressure cap while the engine is hot. Let the engine cool before opening the pressure cap.

MOVING PARTS CAN CAUSE SEVERE PERSONAL INJURY OR DEATH

- Do not remove any belt guards or covers with the generator set running.
- Keep hands and loose clothing away from moving parts. Do not wear jewelry while servicing any part of the generator set.
- Never step on the generator set (as when entering or leaving the engine compartment). It can stress and break unit components, possibly resulting in dangerous operating conditions from leaking fuel, leaking exhaust fumes, etc.
- Before performing any maintenance on the generator set, disconnect its batteries to prevent accidental starting. Do not disconnect or connect battery cables if fuel vapors are present. Ventilate the generator set compartment or bilge thoroughly with the power exhauster.

ELECTRICAL SHOCK CAN CAUSE SEVERE PERSONAL INJURY OR DEATH

- Do not make adjustments in the control panel or on engine with unit running. High voltages are present. Only qualified service personnel, standing on dry surfaces to reduce shock hazard, should be allowed to work on the unit while running.
- **DO NOT CONNECT THE GENERATOR TO ANY BUILDING/MARINA ELECTRICAL SYSTEM.** Electro-cution or damage to property could occur at a site remote from the boat where line or equipment repairs are being made. A ship-to-shore transfer switch must be installed to prevent interconnection of generator set power and shore power.
- Do not work on this equipment when mentally or physically fatigued or after consuming any alcohol or drug that impairs judgment or abilities.

Table of Contents

SUBJECT	PAGE
SECTION 1. OPERATION.....	1-1
Prestart Checks.....	1-1
Starting Engine.....	1-2
Operation Recommendations.....	1-3
SECTION 2. MAINTENANCE.....	2-1
Service Intervals.....	2-1
Bleeding the Fuel System.....	2-2
Checking Engine Oil.....	2-3
Changing Engine Oil & Filter.....	2-4
Filling and Draining Cooling System.....	2-5
Replacement of Zinc Anode.....	2-6
Replacement of Water Pump Impeller...	2-6
Adjustment of Alternator Belt.....	2-7
Inspection and Replacement of Air Filter.	2-8
GENERATOR STORAGE.....	3-1
GENERATOR INSTALLATION.....	4-1
WIRING DIAGRAMS	

California Proposition 65

⚠ WARNING ⚠

The engine exhaust from this product contains chemicals known to the State of California to cause cancer, birth defects or other reproductive harm.

Section 1. Operation

Prestart Checks

For best operation and continued satisfaction, the following should be checked daily.

Air Intake System: Hoses and other components of the air intake system should be examined for cracks or any other cause of unfiltered air entering the engine. See section 2 Scheduled Maintenance.

Battery: For batteries with filler caps, remove the caps and check the electrolyte level of each cell. Add distilled water if necessary. Check cables for corrosion or chafing. If such is noted, have a qualified service technician make appropriate repairs. See section 2. Scheduled Maintenance

Generator Compartment: Keep the generator compartment clean and dry. Check for fuel, oil or coolant leaks. Examine exhaust piping, hoses and muffler for leaks. If any leaks are noted, have a qualified service technician make repairs.

Fuel Level: Make sure adequate fuel is available for the period of operation. See section 2. Scheduled Maintenance.

Oil Level: Remove dipstick and check oil level. Oil should register at or near the FULL mark. If necessary, add oil to bring level up to this range. See section 2 Scheduled Maintenance.

Cooling System: If equipped with a coolant recovery tank, check that the coolant level is between the ADD/COLD and the FULL/HOT marks on the side of the tank. It is recommended that the coolant pressure cap be periodically removed and check that the coolant level is full. On units without a coolant recovery tank, remove the pressure cap to check the coolant level.

⚠ WARNING

Hot coolant can cause severe burns.

Do not remove the coolant pressure cap while the engine is hot. Allow the engine to cool and release the pressure from the system before removing the cap. To release the pressure, cover the cap with a thick cloth and turn it slowly counterclockwise to the first stop. After pressure has been released, remove the cap. Add coolant as necessary.

Important : If the coolant level has dropped due to evaporation, add only water to the system to maintain a 50/50 anti-freeze mix ratio. If level has dropped due to leakage or spillage, add a pre-mixed solution of 50/50

water and anti-freeze. Severe engine damage could occur if mixture exceeds the 50/50 ratio.

Check the water pump/alternator belt for proper tension. If loose, adjust it to appropriate tension. See section 2 Scheduled Maintenance.

1-1

Starting the Engine

After completing the prestart checks, open the manual fuel shut-off valve (if equipped). Turn the Off/Run switch to the Run position. Move and hold the Start/Preheat switch to the Preheat position and hold for approximately 5 seconds. Next, move the Start/Preheat switch to the Start position and the engine should start. Immediately release the switch when the engine starts.

stop solenoid and activate the starter for about 10 seconds to allow oil to reach engine parts.

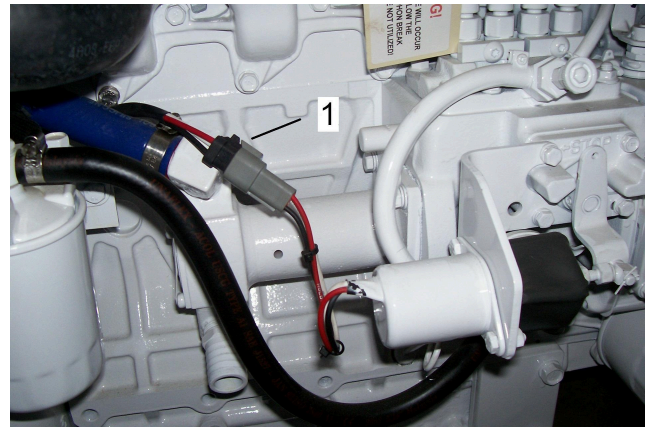

(1) Stop Solenoid Plug

CAUTION

DO NOT USE ETHER OR ANY STARTING FLUID FOR STARTING THE ENGINE. SEVERE ENGINE DAMAGE CAN OCCUR.

IMPORTANT: When starting the engine after storage time of over 3 months, first un-plug the

NOTE: If the engine fails to start after the first attempt, close the raw water seacock before attempting additional starts. Failure to close the seacock when excessive cranking without starting may cause exhaust piping and silencer to fill with seawater. This may further hinder starting and cause seawater to enter the engine through the exhaust valves.

IMPORTANT: If the engine does not start after cranking for 10 seconds, wait for 30 seconds to begin the sequence again. Failure to follow these guidelines may result in damage to the starter by overheating. If engine does not start after 3

attempts, contact an authorized Phasor Marine dealer.

NOTE: Failure to open the seacock after generator is running will result in serious engine

damage due to over heating and will also cause damage to seawater pump impeller.

IMPORTANT: Be sure to allow the engine to warm up, not only in winter, but also in warmer seasons before applying load. An insufficiently warmed-up engine can shorten its service life.

1-2

Operating Recommendations

BREAK-IN PROCEDURE

After 50 hours of operation, change engine oil and oil filter. See section 2. Scheduled Maintenance

NO-LOAD OPERATION

Keep no-load operation to a minimum. With no load on the generator, combustion chamber temperatures drop so low that the fuel does not burn completely. This creates carbon deposits which clog injectors, glaze cylinder walls and cause valves and piston rings to stick. If it is necessary to run the generator for a long period, connect an electrical load to the generator.

EXERCISE PERIOD

Infrequent or short use can result in difficulty in starting and moisture condensation problems. This moisture is a result of the engine not being run long enough to reach normal operating temperature. In extreme cases, water may be deposited in the engine oil. If this happens, severe engine damage can occur. To prevent this from happening, run the generator set under load for at least one hour per week.

Exercising for one long period each week is better than several short periods. DO NOT

operate the generator for long periods without a load.

Color of Exhaust

While the engine is running within the rated output range, the exhaust remains colorless. If the output slightly exceeds the rated level, the exhaust may become colored. If the engine is run continuously with dark exhaust emission, severe engine damage may occur.

Stopping the Engine

Allow the Generator to run with no load for 5 minutes to cool down. Move switch to the off position

Circuit Protection

AC Circuit Breaker

The AC circuit breaker will trip if a fault is detected in the output circuit. After the fault is corrected, reset the AC breaker by moving it to

the “OFF” position and then to the “ON” position. The generator is now ready to be restarted.

DC Fuse

A 40 amp fuse is located in the wire harness near the starter. This fuse will blow if a fault is detected in the DC circuit. If the fuse blows, find the cause of the fault and repair. Replace the fuse to operate the unit.

Section 2. Scheduled Maintenance

Following the maintenance schedule and using the generator set properly will result in longer generator life, better performance and safer operation. Perform each maintenance procedure at the time period indicated or after the number of operating hours indicated, whichever comes first. Refer to the *maintenance procedures* section for these procedures.



WARNING

Accidental starting of the generator set during maintenance can cause severe personal injury or death. Disconnect both generator battery cables before performing maintenance. Remove the negative (-) cable first to reduce the risk of arcing.

Service Intervals

Observe the following for service and maintenance.

The lubricating oil change intervals listed in the table below are for classes CF, CE, and CD lubricating oils of API classification with a low-sulfur fuel in use. *If the CF-4 or CG-4 lubricating oils are used with a high-sulfur fuel, change the lubricating oil at shorter intervals than recommended in the table below depending on the operating conditions.*

Interval	Item	Ref. Page
Daily or after 8 hours	Check oil level	2-3
	Check coolant level	2-5
Every 50 hours	Check fuel pipes and clamps	
See NOTE:	Change engine oil	2-4
Every 100 hours	Check air cleaner element	2-8
	Check battery level and connections	
	Check fan belt tension	2-7
Every 200 Hours	Check cooling hoses and clamps	
	Check air intake hose	
	Change engine oil and filter	2-4

Every 400 hours	Change fuel filter cartridge	2-2
Yearly or after 500 hours	Change air filter element	2-8
	Check genset brushes (If applicable)	To be performed by qualified service tech.
	Flush and clean cooling system	2-5
Every 800 hours	Check valve adjustment	See Workshop Manual
Every 1500 hours	Check fuel inj. nozzle injection pressure	To be performed by qualified service tech.
Every 2 years	Change engine coolant	2-5

Note: Engine oil must be changed after initial 50 hours and every 200 hours thereafter.

2-1

Maintenance Procedures

Periodic Service

Air bleeding the fuel system

7- Turn generator off.

▲ CAUTION

▲ CAUTION

To avoid personal injury, do not bleed a hot engine. This could cause fuel to spill onto a hot exhaust and create a danger of fire.

Be sure to wipe up any fuel that may have spilled.

Air bleeding of the fuel system is required if:

- 1- The fuel filter or fuel lines have been replaced
- 2- The generator has run out of fuel
- 3- The generator is to be used after a long storage period

Procedure

- 1- Loosen the air vent plug on the fuel filter a few turns.
- 2- Turn the power switch on.
- 3- When air bubbles stop coming from around bleed screw, tighten the screw.
- 4- Open the air vent cock on top of the fuel injection pump.
- 5- Start the generator set.
- 6- When the engine runs smoothly, close the air vent cock.

IMPORTANT:

- Always keep the air vent cock on the fuel injection pump closed except when air is vented, or it may cause the engine to stop.

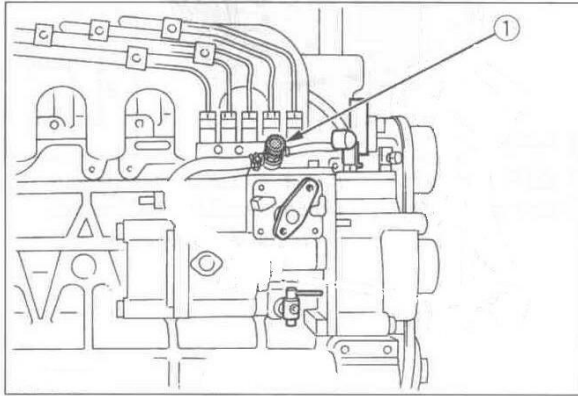

(1) Air vent cock

Fuel filter replacement

- 1- Replace the fuel filter cartridge every

400 hours of operation.

- 2- Thinly apply diesel fuel over the sealing o-ring and hand-tighten only.
- 3- Bleed the fuel system of air

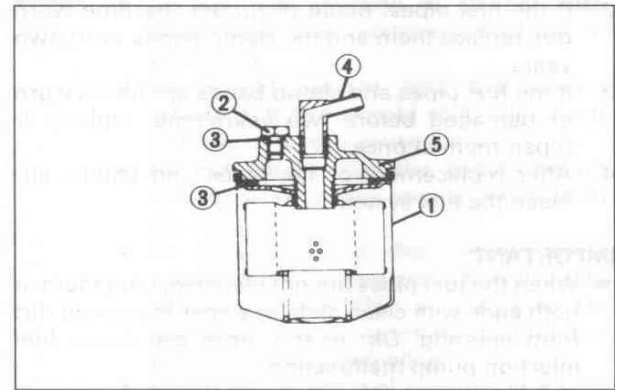

(1) Fuel filter cartridge
(2) Air vent plug
(3) O ring
(4) Pipe joint
(5) Cover

2-2

Engine Oil

● **CAUTION**

To avoid personal injury:

- Be sure to stop the engine before checking or changing the engine oil and the oil filter.
- Contact with engine oil can damage your skin. Wear protective equipment. If you come in contact with the engine oil, wash it off immediately.

Note:

If engine is not level, the oil level will not be measured properly.

Checking oil level and adding engine oil

1. Check the engine oil level before starting or more than 5 minutes after stopping the engine.

2. Remove the oil level gauge, wipe it clean and reinstall it.
3. Take the oil level gauge out again and check the level.
4. If the oil level is too low, remove the oil filler cap and add oil to the prescribed level.
5. After adding oil, wait 5 minutes and check the oil level again. It may take some time for the oil to drain to the oil pan.
6. If the engine is operated with the oil at the lower limit, the oil may deteriorate quickly. It is recommended that the oil be kept near the upper limit.

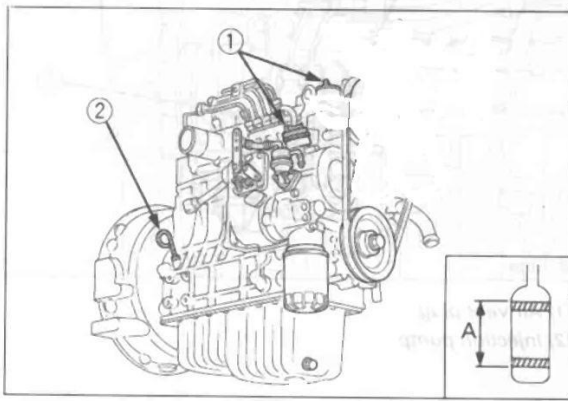

(1) Oil filler plug [Lower end of oil level gauge]
 (2) Oil level gauge (A) Engine oil level within this range is proper.

Engine oil quantity

Model	Quantity
K3-15.0	5.6 L (1.45 U.S. gals.)
K4-16.0 Thru K4-21.0	7.6 L (2.01 U.S. gals.)

K5-27.0	12.0 L (3.17 U.S. gals.)
---------	--------------------------

IMPORTANT:

Engine oil should be MIL-L-2104C or have API classification of CD grade or higher.

The table below list the type of engine oil according to the ambient temperature.

Above 25°C (77°F)	SAE30 or SAE10W30 SAE10W-40
0 to 25°C (32 to 77°F)	SAE20 or SAE10W-30 SAE10W-40
Below 0°C (32°F)	SAE10 or SAE10W-30 SAE10W-40

When using a brand of oil different from the previous one, be sure to drain all of the previous oil before adding the new oil.

2-3

Changing the engine oil

- **CAUTION**

To avoid personal injury:

- Be sure to stop the engine before draining the engine oil.
- When draining the engine oil, be sure to capture it in a appropriate container and dispose of it according to local regulations.
- Do not drain the oil immediately after running the engine. Allow the engine to cool down sufficiently. Hot oil can cause burns.

1. Change the engine oil after the initial 50 hours of operation and every 200 hours thereafter.
2. Open the drain valve located on the front of the engine oil pan and drain all of the engine oil.

3. Close the drain valve.
4. Add new engine oil to the upper limit of the oil dipstick.

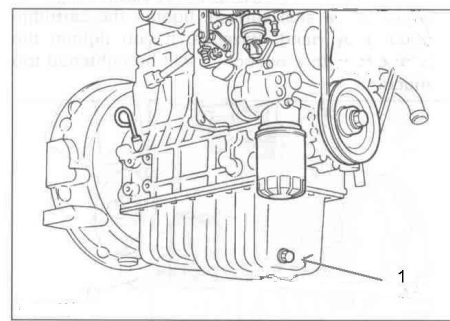

(1) oil drain valve

Replacing the oil filter cartridge

- **CAUTION**

To avoid personal injury:

- Be sure to stop the engine before changing the oil filter cartridge.

- **Allow the engine to cool down sufficiently. Hot oil can cause burns.**

1. Replace the oil filter cartridge after the initial 50 hours of operation and every 200 hours thereafter.
2. Remove the old oil filter cartridge with a filter wrench.
3. Apply a thin film of oil to the new filter gasket.
4. Spin the filter on until the gasket makes

5. Turn the filter an additional $\frac{3}{4}$ turn. **Do not overtighten.**
6. After the new filter has been replaced, the oil level normally decreases. Run the engine for a short period of time and check for leaks. Recheck the oil level and add if necessary.

Note:

Wipe off any oil that has spilled.

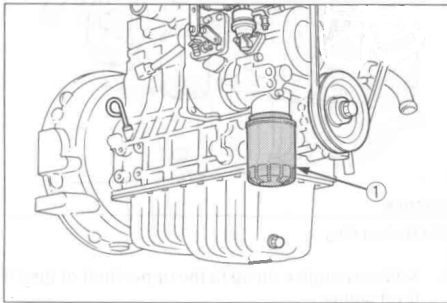

(1) oil filter cartridge
Remove with a filter wrench
(Tighten with your hand)

2-4

Cooling System

Coolant Requirements

The engine coolant must inhibit corrosion and protect the engine from freezing. A 50/50 mixture of ethylene glycol anti-freeze and water is recommended for normal operation and storage. Use only a reliable brand of anti-freeze that contains a rust and corrosion inhibitor.

Note:

The anti-freeze should not contain any type of a stop leak additive.

Do not exceed a 50/50 mixture of ethylene glycol and water. A higher concentration of ethylene glycol will alter the heat transferring properties of the coolant. A 50/50 mixture will provide freeze protection to -34 degrees.

Water used in the coolant mixture should be clean, low in minerals and free from corrosive chemicals. Use distilled or soft water if available. Avoid use of well water, which may contain minerals, which can clog the heat exchanger and reduce the cooling efficiency.

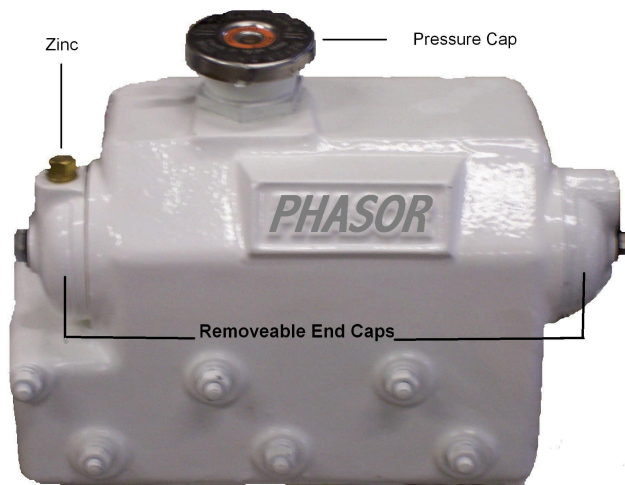

Filling the Cooling System

Make sure that all of the drain cocks are closed and hose clamps are tight. Open the air bleed valve on top of the thermostat housing. Remove the cooling system pressure cap and slowly fill the cooling system with a pre-mixed 50/50 coolant mixture. When coolant reaches the air bleed valve, close the valve. Continue to fill the system until full. Start the engine and allow it to reach operating temperature. Allow engine to properly cool down and slowly remove pressure

Zinc Anode

The anticorrosion zinc anode is installed to prevent electrolytic corrosion by the seawater. When different metals, such as iron and copper, are placed in a highly conductive liquid such as seawater, the iron gradually rusts. The anticorrosion zinc anode has chemical properties which cause the seawater to react to it rather than the engine components.

The anticorrosion zinc anode should be checked initially at 3 months. Replace anticorrosion zinc as necessary. Depending upon operating conditions and the properties of the seawater, the anticorrosion zinc anode may have to be replaced

cap. Check coolant level and add if necessary.

Draining the Cooling System

Allow the engine to properly cool. To drain the coolant, open the drain cock located on the starter side of the engine. Remove the pressure cap to aid in draining.

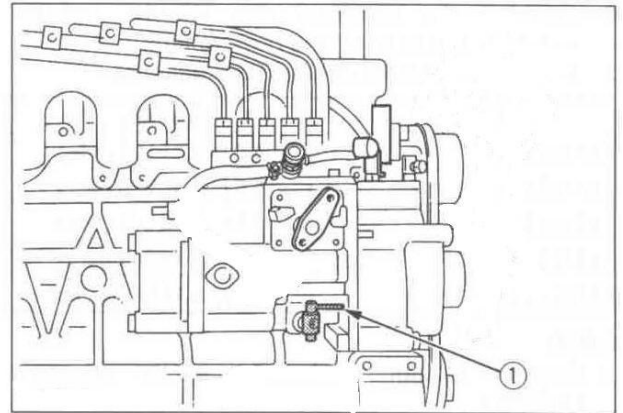

(1) Coolant drain cock

2-5

more often.

Inspection and Replacement of Zinc Anode

- 1- Disconnect battery, negative lead first.
- 2- With Generator set cool, close seacock.
- 3- Remove anticorrosion zinc anode. See page 2-5 for location.
- 4- Use a wire brush to remove the loose corrosion on the zinc anode. Replace when less than 50% of the .035 in. dia. X ¾ in. long portion of zinc remains.
- 5- Clean threaded hole of heat exchanger and coat threads of the zinc anode with pipe joint

compound before installing.

- 6- Open seacock.
- 7- Reconnect the battery, negative lead last.
- 8- Start the generator and check for leaks.
Check for pump operation by observing water discharge from the exhaust outlet.

Siphon Break Valve

A siphon break valve is used to prevent sea water entry into the engine when the exhaust manifold is located less than 9 inches above the water line when the craft is loaded to the maximum capacity and is shutdown. When used in contaminated waters or salt water, the formation of corrosion may prevent the siphon break to function properly. Check the valve routinely to ensure proper operation.

Sea Water Pump

The Phasor Compact Series use a direct driven sea water pump located on the service side of the

engine. The water pump impeller should be changed yearly.

Inspection and Replacement of Impeller

- 1- Disconnect battery, negative lead first.
- 2- With Generator set cool, close seacock.
- 3- Remove the 4 screws attaching the rear cover plate.
- 4- Grasp the impeller and slide off the water pump shaft.
- 5- Wipe any foreign material from housing.
- 6- Inspect inside of water pump housing for scratches or damage. If damaged, replace pump.
- 7- Apply a small amount of grease to the inside of the pump housing.
- 8- Install the new impeller by aligning the flat part of the shaft and the flat part of the impeller.
- 9- Install new cover o-ring and install rear cover plate.
- 10- Open seacock.
- 11- Reconnect battery, negative cable lase.
- 12- Start the generator and check for leaks.
Check for pump operation by observing water discharge from the exhaust outlet.

Belt Tension



CAUTION

To avoid personal injury:

- **Be sure to stop the engine and remove the battery cables before checking the belt tension.**
- **Be sure to reinstall the front belt guard after checking or adjusting the belt tension.**

Proper belt tension	A deflection of between 7 to 9 mm (0.28 to 0.35 in.) when the belt is pressed in the middle of the span.
---------------------	--

1. Stop the engine and remove the battery cables. Disconnect the negative lead first.
2. Remove the front belt guard by removing the three 6mm bolts.
3. If the belt is damaged, replace the belt.
4. Apply moderate thumb pressure to the belt between the alternator and the crankshaft pulley.
5. If the tension is incorrect, loosen the alternator mounting bolts and place a lever between the alternator and the engine block. Pull the alternator out until the deflection of the belt is within limits.
6. Tighten the alternator mounting bolts.
7. Install the front belt guard.
8. Install the battery cables. Connect the negative

lead last.

IMPORTANT:

If the belt is loose or damaged, it could result in engine overheating or insufficient charging of the battery.

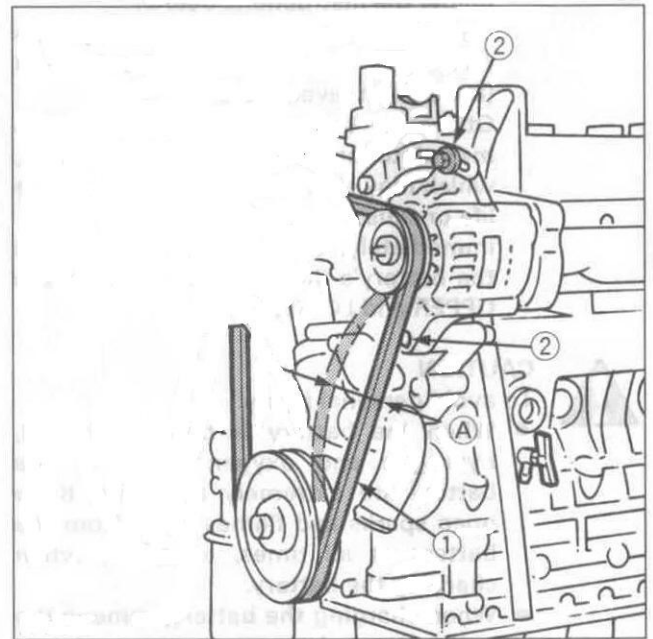

(1) Fan belt

(2) Bolt and nut

(A) 7 to 9 mm (0.28 to 0.35 in.)

(under load of 10 kgf (22.1 lbs))

Air Cleaner

Inspection and Replacement

1. To inspect the air cleaner element, loosen the three attaching clips.
2. Remove the end cap.
3. Pull out on the element while gently moving it side to side.
4. Inspect element for excessive dirt or damage.
5. If element is dirty or damaged, replace it. Do not attempt to clean it.
6. Install new element in housing and press it gently over the sealing tube. The element seals on the inside area.
7. Install end cap aligning notches. The cap will fit in many orientations.
8. Return attaching clips to their original position.

position.



Section 3. Generator Set Storage

Out-of-Service Protection

It is recommended that the craft be afloat at the time of generator set storage since the generator must be started.

1. Start the generator set and run until operating temperature is reached.
2. Stop the generator set.
3. Allow the generator set to cool sufficiently and drain the oil while the engine is still warm.
4. Change the oil filter.
5. Refill the crankcase with specified oil.
6. Check the coolant level. Add more coolant if necessary. If freezing temperatures are possible, test the coolant mixture.
7. The seawater cooling system must be drained of water or protected with a 50/50 antifreeze mixture as follows:

To drain

- A. Close the seacock and remove the raw water hose at filter. Leave seacock closed.
- B. Drain the water from the hose.
- C. Remove the rear cover on the seawater pump and drain any water.
- D. Remove the drain plug, located on the bottom of the exchanger above the starter, and drain.
- E. Drain any water from exhaust system.

50/50 method

- A. Close the seacock and remove the raw water hose at filter. Leave the seacock closed.
- B. Place the hose in a container with a mixture of 50/50 antifreeze mixture.



CAUTION

To avoid personal injury:

- Be sure to stop the engine before draining the engine oil.
- When draining the engine oil, be sure to capture it in an appropriate container and dispose of it according to local regulations.
- Do not drain the oil immediately after running the engine. Allow the engine to cool down sufficiently. Hot oil can cause burns.

C. With a suitable container at the exhaust outlet, run the generator set.

D. When the mixture is observed coming out of the exhaust, stop the engine.

Note:

Do not allow the coolant mixture to flow into waterways.

8. Disconnect battery. Negative lead first



DANGER

Battery electrolyte can cause severe eye damage and burns to the skin. Wear goggles, rubber gloves and a protective apron when working with batteries.

9. Remove battery and store in a warm dry location. Connect a trickle charger once a month to maintain a full charge.

10. Clean the generator set and spread a light film of oil or silicon spray over any exposed surfaces which may be subject to rust or corrosion.

Returning to Service

1. Remove any plugs or covers installed for out-of-service protection.
2. Check engine oil and coolant levels.
3. Open seacock.
4. Install battery, installing the negative cable last.
5. Prime fuel system.
6. If 50/50 method was used for storage, use appropriate container to catch antifreeze from exhaust.
7. Start generator set and allow to run at no load for 5 minutes.
8. Inspect for any fuel, water or oil leaks.
9. After warm up, apply load of at least 50 percent rated output.
10. Check gauges for normal readings.
Generator is now ready for service.



Battery electrolyte can cause severe eye damage and burns to the skin. Wear goggles, rubber gloves and a protective apron when working with batteries.



Section 4. Installation

Locating The Generator

Every vessel will have an ideal or preferred spot for a generator. Ambient air temperature must be considered when selecting a location for the generator. Even though most marine engines are water cooled, there will always be radiant heat from the engine. Also, many generator ends are air cooled with their own internal fan, thus adding more heat to the compartment. This affects the air needed by the engine for combustion. Remember, combustion air temperature will affect performance. If the ambient air temperature in the compartment exceeds 120 degrees F., significant loss of performance may occur.

Location Checklist

- Ambient Air Temperature
- Clearance for proper Exhaust System pathway
- Proper elevation for Percolating Muffler location
- Access to Raw Water for Heat Exchanger
- Access to cool Combustion Air
- Ample clearance for support structure and platform

Extended operation at ambient air temperatures above 120 degrees F. may damage the unit. (Most engine generator manufacturers will provide operating specifications.) The compartment should be well ventilated. If necessary, forced air flow must be installed.

This temperature problem is not unique -- it affects all engines. Engine output ratings are commonly measured at an ambient temperature of 68 degrees F. at sea level. A typical de-rating is 3% per 20° F. increase above ambient temperature. Most installations never get involved with this problem, however, we have seen installations in the main engine room where ambient temperatures were as high as 130 degrees F.

MOUNTING

The unit should be securely fastened to a strong, stiff, platform. The platform should be marine grade plywood at least 1" in thickness. Two 3/4" sheets, glued and screwed together are ideal. Anything less will result in vibration of the platform and create noise in the boat. The platform should be supported by stiff structural members secured to the vessel.

RAW WATER FOR COOLING

A raw water thru hull dedicated to the exclusive use of the generator is preferred. It should consist of a seacock with not less than a 1" I.D. hose connection, a sea strainer with cleanable screen, and wire reinforced hose that will not collapse from suction or bending.

If the generator is going to be installed on a "high speed" boat, the raw water intake should NOT be of the forward facing scoop type. The ram effect of high speed planing may force water through the scoop and into the raw water cooling system. It is possible to force the water hard enough to fill the percolating muffler, back fill the exhaust hose, and flood the engine. There is only one way to avoid this; close the sea cock when the generator is not running. For convenience, a remotely operated electric solenoid valve can be used to protect the engine. Be sure to use a corrosion resistant valve compatible with the raw water.

Note:

These are only guidelines for installation. The ultimate responsibility for proper installation belongs to the installer.

Exhaust System design

The engine is equipped for a "wet marine" exhaust system. That is, the waste raw water is injected into the exhaust elbow and sprayed into the hot exhaust gases to cool them. The cooled waste water and exhaust gas mix is then disposed of through a marine "percolating" type muffler and a 2" I.D. marine grade, wire reinforced exhaust hose. The rear of the enclosure has a hole for the exhaust hose to pass through so it can be secured to the exhaust elbow on the engine.

Percolating mufflers are available from several manufacturers with different brand names. Aqualift, Water Lock, Water Lift, etc., are just a few. They all operate on the same principle. The device is divided into two sections. A large surface area on the input side, and a small surface area on the outlet side. A vertical baffle divides the two sections from the top to just above the bottom. The mixed water and exhaust gas is fed into the top or side of the percolator. The water falls to the bottom of the percolator and the gas escapes around the bottom of the baffle and through the outlet. As the water level rises, the opening to the outlet side is blocked and the gas is trapped in the input side. Exhaust gas pressure (back pressure) increases and applies a force to the large surface area of the water. Ultimately this force reaches sufficient strength to "lift" some of the water up the outlet side to the outlet port. This "percolated" water proceeds upward to the high point of the exhaust system, crosses over the high point, then gravity flows to the exhaust thru hull and overboard. There are several critical points to consider.

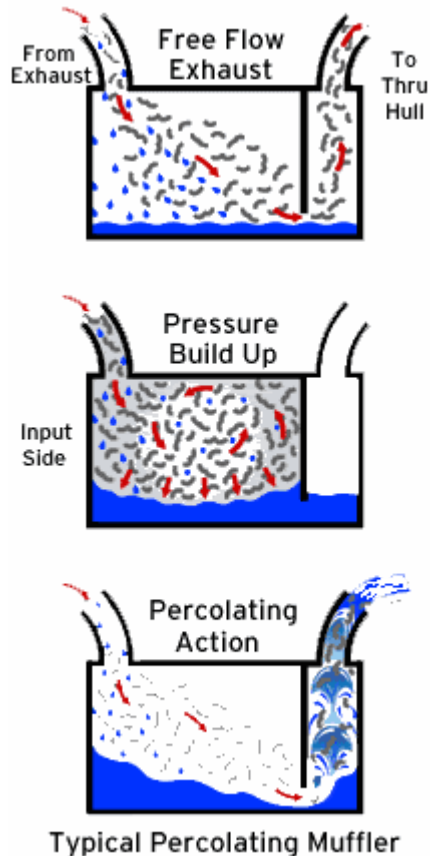

Typical Installation

In a typical installation, that is, one in which the generator is located above the waterline, the exhaust elbow on the engine must be at least 12" above the waterline, in all conditions.

4-2

Percolator Inlet

The inlet to the percolator muffler must always be 4" or more below the exhaust elbow outlet of the engine, including the effects of pitch and roll on the vessel. The connection should be within a reasonable horizontal distance. Never loop up and down. Always proceed in a steady downward direction.

Percolator Outlet

The outlet of the percolator should be connected to 2" I.D., wire reinforced, marine grade exhaust hose. The hose should run in a vertical or near vertical direction until it reaches at least 10" above the vessel waterline. At that point it can be curved over and should continue in a downward direction to the exhaust thru hull. The horizontal distance from the top of the curve to the thru hull has no limit on length; however, once the hose starts its downward direction it must never loop up and down. If in doubt, call us for consultation.

When a typical marine exhaust system is installed with the thru hull mounted above the vessel's waterline, it is not unusual to hear a "whooshing" noise on the outside of the vessel near the exhaust outlet. This can be reduced, or in some cases eliminated, with the installation of one or two inline exhaust silencers. Be sure to select a silencer that does not restrict the exhaust flow and create "back pressure."

When to Use an Anti-Siphon Exhaust

If the mid-line of the unit is to be installed at or below the waterline of the vessel, a siphon break must be used. Either a "valve" or "tee" type can be used.

Siphon Break Valve

The valve must always be at least 10" above the waterline, regardless of the pitch and roll of the vessel. There is no maximum height. Commercially available anti-siphon valves are fairly reliable; however, they do get fouled and can stick in either the open or closed position. Regular maintenance is necessary.

Siphon Break Tee

The "tee" method is a more reliable type of siphon break. The tee is generally designed with hose barbs on the input and output connections and a smaller connection on the branch. The branch hole should be restricted to 1/8" dia. Mount the tee a minimum of 10" above the vessel's waterline. The branch side of the tee is connected to an overboard thru hull, also mounted above the waterline. Or, the branch side of the tee can be tapped into the exhaust hose, after the Silencers. The hose from the branch should always flow in a continuous up or down direction. Never loop the hose up and down. If in doubt, call us for consultation. The thru hull should be mounted so it is always vented to atmosphere, never under water.

Connections for Anti-Siphon System

Remove the hose that connects the heat exchanger to the exhaust elbow Inlet. Install a new wire reinforced hose between the heat exchanger and the inlet of the anti-siphon device. Install a second wire reinforced hose between the outlet of the siphon break and the exhaust water Inlet on the exhaust elbow.

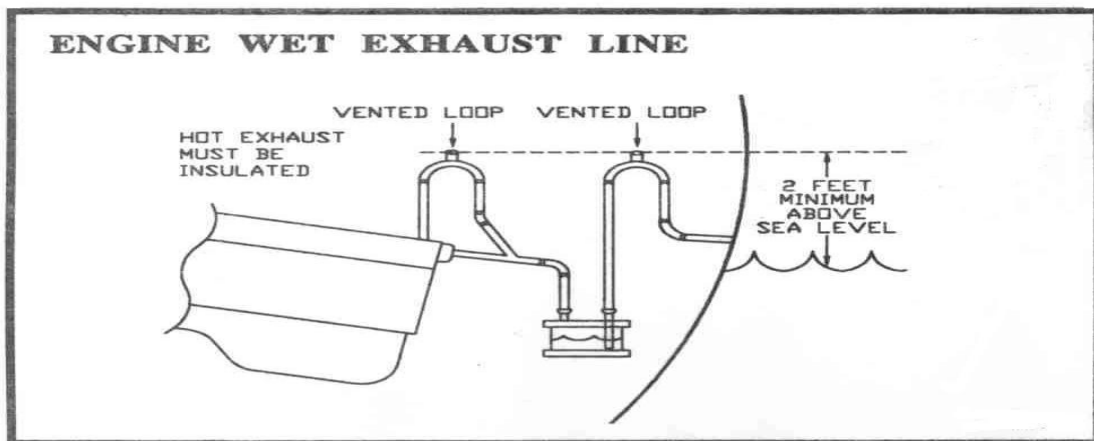

4-3

A.C. Wiring

Wiring Color Codes

In the United States, commercial and domestic wiring follows a color code established by the National Electrical Manufacturers Association (NEMA). Three wires are used for standard 120 volt circuits. A black color is used for the 120 volt

"hi side," a white wire is the "Low side," and a green wire is used for earth ground. If you measure the voltage between the black and white wires, you will measure 120 volts. If you measure the voltage between the black and green wires, you will measure the same 120 volts. This is because the white wire and green wires are connected together at the power distribution transformer. Vessels built in the U.S. normally follow this three wire system. The main shore cable also has a black, white, and green wire. The black and white wires go to the vessel's main circuit breaker, while the green wire goes to the vessel's ground buss.

Polarity Indicators

Vessels equipped with polarity indicators can monitor the local dock power for correct polarity. This can be quite helpful. Many older dock power outlets do not follow the NEMA wiring code, and can be hazardous to you and your vessel. Some foreign built vessels do not follow the NEMA code either. In fact, we have seen some that are genuinely confusing, even to the point of changing from one color to another along the length of the wiring harness.

Earth Ground

The output winding on the generator is not grounded to the frame (earth ground). We provide a two wire system; a black "Hi side," and a white "Low side." Electrically, the output is "floating" and has no reference to the "earth." If you wish to establish an earth ground reference for the generator output, add a jumper wire from the white wire "Low side" to the chassis of the engine generator. Then, connect a green earth wire from this new point to the vessel's ground buss.

Ship/Shore Switch

A proper system should include a "ship/shore" switch so the vessel can be powered from either shore power or generator power. This is a special switch used to disconnect the vessel's main breaker from the shore power cable and connect it to the generator, and vice versa. Connect both the black "Hi side" and the white "Low side" wires to a set of "input" terminals on the switch. Disconnect the shore power cable from the master circuit breaker, and reconnect it to the other set of "input" terminals on the switch. The "output" set of terminals is then connected to the master breaker. Some vessels have split systems with two shore power cables. If you have this arrangement, call us for a technical consultation and we will explain your options. If you have, or plan to install, a D.C. to A.C. inverter for occasional A.C. power, you may also wish to call us for a technical consultation.

Circuit Breaker. The generator is rated for a specific output, so the same amperage (or lower) circuit breaker should be installed in the A.C. circuit for generator protection.

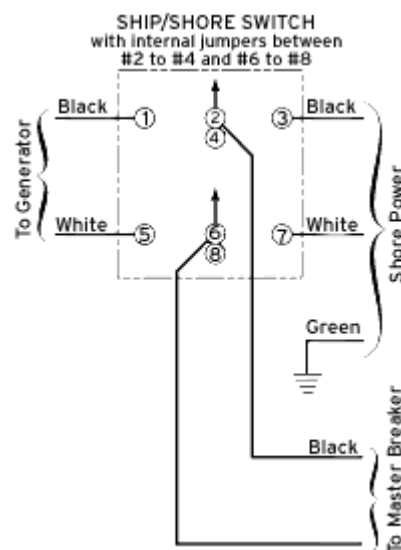

12 Volt D.C. Battery Connections

The starter motor on the engine draws approximately 60 amps during cranking. Use wire equal to or greater than #4 gauge. The +12 volt terminal on the starter motor will accept a 3/8" ring type wire terminal.

The -12 volt battery cable connection can be made to the engine bracket bolt on the left front side of the engine. A 3/8" ring terminal will fit the bolt.

Typical starting time is 3 to 7 seconds for a properly operating engine. This translates into 0.1 ampere hour of power. The D.C. current demand by the unit during normal operation is only 1 amp; therefore, it is practical to draw power from the ship's main engine battery. Connection can be made at either the battery switch or the engine. If a separate battery is to be dedicated to the generator, a small trickle type battery charger can be used to keep the battery fully charged. A charger capacity of 1 amp is more than adequate. It should be noted, that since the unit only requires 1 amp of D.C. power to operate, hand crank starting in an emergency can easily be accomplished. Even though the battery may not be able to turn the engine over, it will almost always have sufficient reserve to provide 1 amp for running. A couple of 6 volt lantern batteries, connected in series, will also provide the power needed.

Fuel Connections

The unit is equipped with a 5/16" hose barb on the fuel transfer pump for fuel "in" and a 3/16" hose barb on the injector leak-off rail for fuel "return." Although the engine is equipped with a "final" filter, there should be a primary filter/water separator device between the tank and the generator. We recommend a filter that is dedicated to the generator, rather than sharing a filter with the "main" engine.

The generator fuel return connection should be directed back to the source tank. Do not draw fuel from one tank and return to another tank. Also, do not return the fuel to the input line. Coast Guard approved hose must be used.

Control Panel

The standard Remote Control Panel is 2 1/4" high by 5" wide. It requires a 1 1/2" x 4" hole in the vessel's bulkhead for clearance (full gauge panel is 6" high by 7 1/2" wide requiring a 4 3/4" X 7" hole). Allow for 3" depth behind the panel. If you cut the hole in the bulkhead first, you can use the panel as a template for the mounting hole pattern. The panel is a pre-wired connection to the Extension Cable supplied. The Extension Cable connects to the generator.

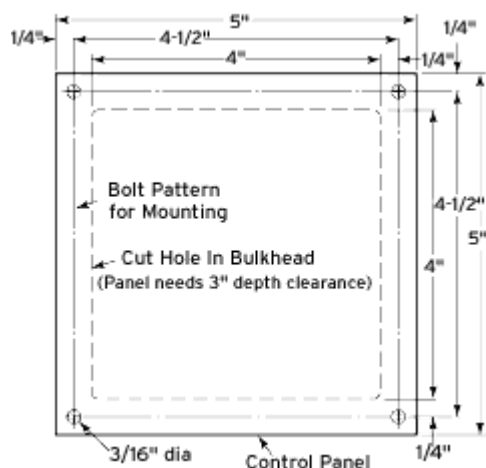

2880 Hammondville Road

Pompano Beach, FL 33069

Tel: (954) 979-5899

Fax: (954) 979-4349

900 Industrial Park Road #10

Deep River, CT 06417

Tel: (860) 526-9773

Fax: (860) 526-2090

PHASOR MARINE
D.C. WIRING DIAGRAM

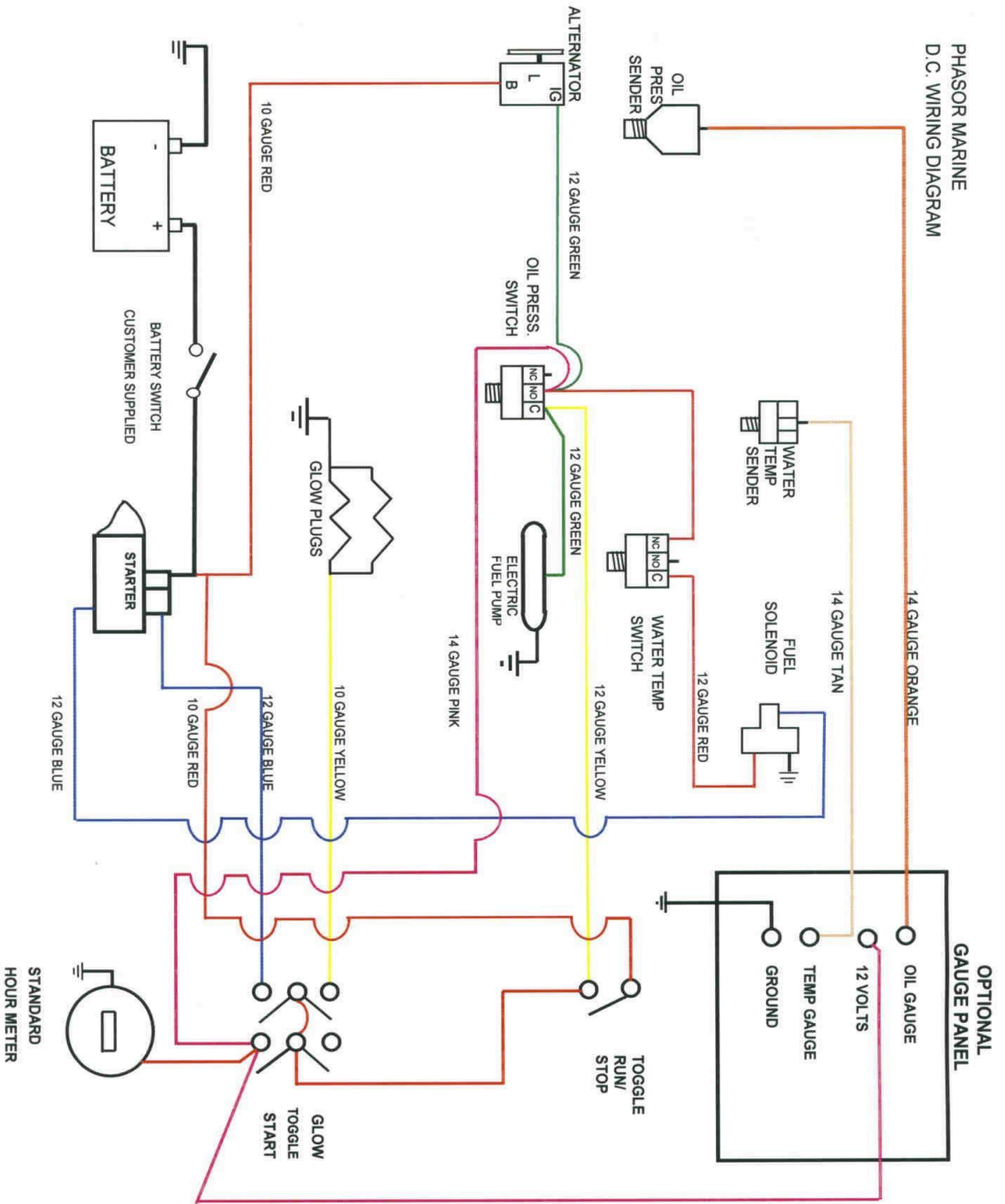

03M DC Wiring

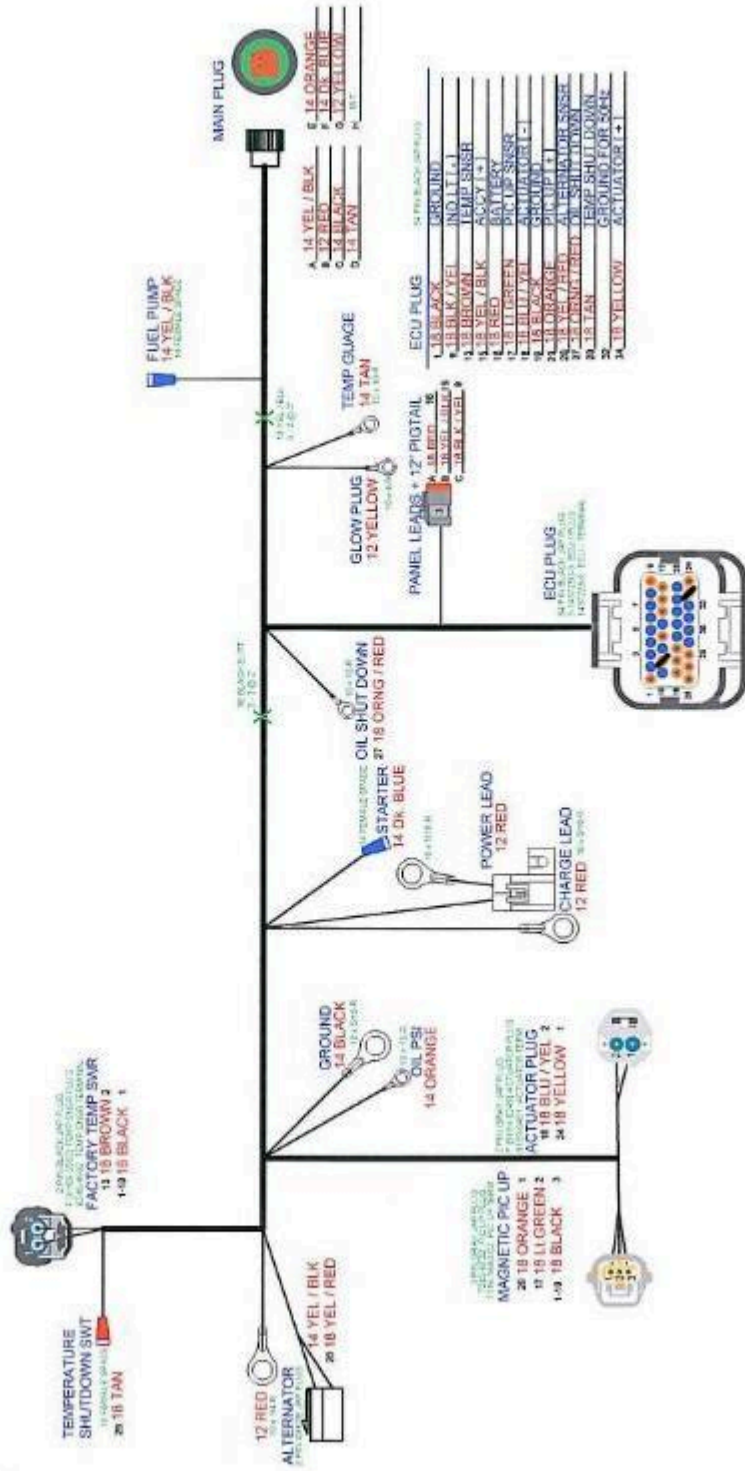

NEWAGE/STAMFORD GENERATOR WIRING SCHEMES

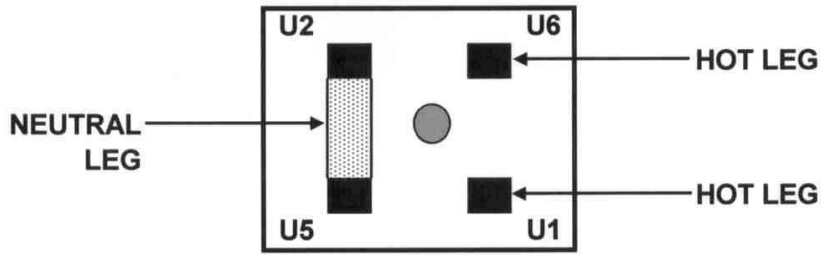

120/240 CONNECTION

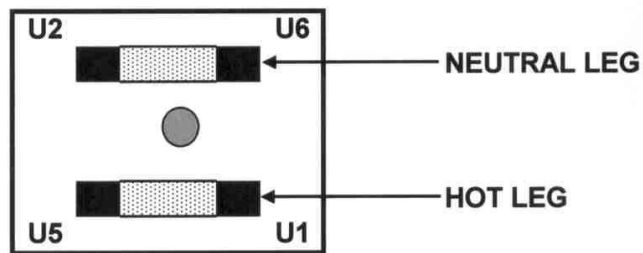

STRAIT 120 CONNECTION

- * JUMPER MUST BE ADDED ON REGULATOR BOARD TO TERMINALS 3 AND 4 FOR STRAIT 120 CONNECTION
- * LEAVE TERMINALS 1 AND 2 AS THEY ARE SET FROM FACTORY

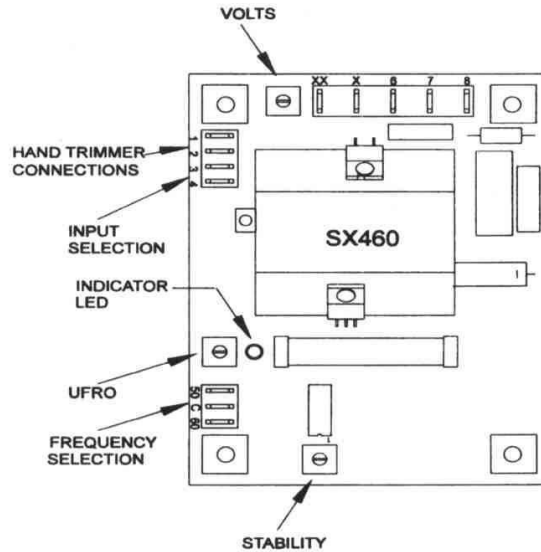

NEWAGE WIRING AND SX460

A12-A401 ^{ISSUE} C IF IN DOUBT-ASK
 FIRST W.O.

MAIN STATOR (4 ENDS)

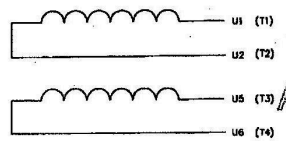

(T1) = NEMA EQUIVALENT

MAIN TERMINAL CONNECTIONS

SERIES 1PH 3W
 V - W = 220...240V
 V - N, W - N = 110...120V

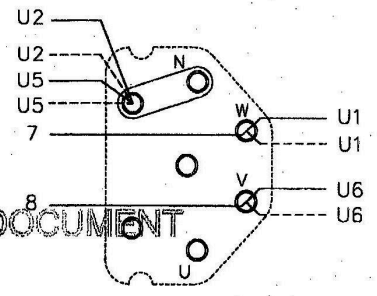

THE ABOVE EXAMPLE SHOWS THE CONNECTION FOR AN 8 LEAD STATOR - 4 LEAD STATOR CONNECTION AS CONTINUOUS LINES ONLY

CONNECTION DIAGRAM			
CERTIFIED PRINT (ONLY IF SIGNED)	FRAME CONTROL	PO/P1 SERIES	OTHER FEATURES
DATE	BY	POLES	
		No. OF ENDS	
		SENSING 2 PHASE	
		CUMMINS GENERATOR TECHNOLOGIES LTD.	A12-A401 ISSUE C
			SHEET 1 OF 1 SHEETS

MOD.	ISS.	DRN.	DATE	ALTERATION
4-346-00	C	AV	30:01:08	PARALLEL 1PH 2W example removed
4-346-00	B	AV	18:07:07	V - W = 220...240V and V - N, W - N = 110...120V added
4-346-00	A	M.C.	21.08.07	ORIGINAL ISSUE